



OWNER'S MANUAL

# Stand For LG LED Screen

---

Please read this manual carefully before install & operating your set and retain it for future reference.

## ST-1364F Stand Installation

## Technical Data

Model Name	ST-1364F
Material	Aluminum , Steel
Surface Finish	Powder Coating (Matte Black)
Recommended Screen Size	136 inch
Allowable Loads	200kg (Maximum)
Height Level	0/200/500mm
Certification	CB,CE-LVD,ETL,RoHS2.0
Stand Dimension (W x D x H)	2497 x 1277 x 1916mm (LEVEL 1) 2497 x 1277 x 2116mm (LEVEL 2) 2497 x 1277 x 2416mm (LEVEL 3)
Caster Size (Diameter)	50mm
Wooden Case Dimension (W x D x H)	2000 x 1392 x 315mm
Weight (Net/Gross)	81kg/175kg

This model (ST-1364F) is a stand for the LAEC015-GN2 AIO model only.

The stand has 3 levels to adjust the height of the screen.

The height can be adjusted if needed, and it is described on the page of 9.

The distance from the floor to the bottom of the screen is shown in the table.

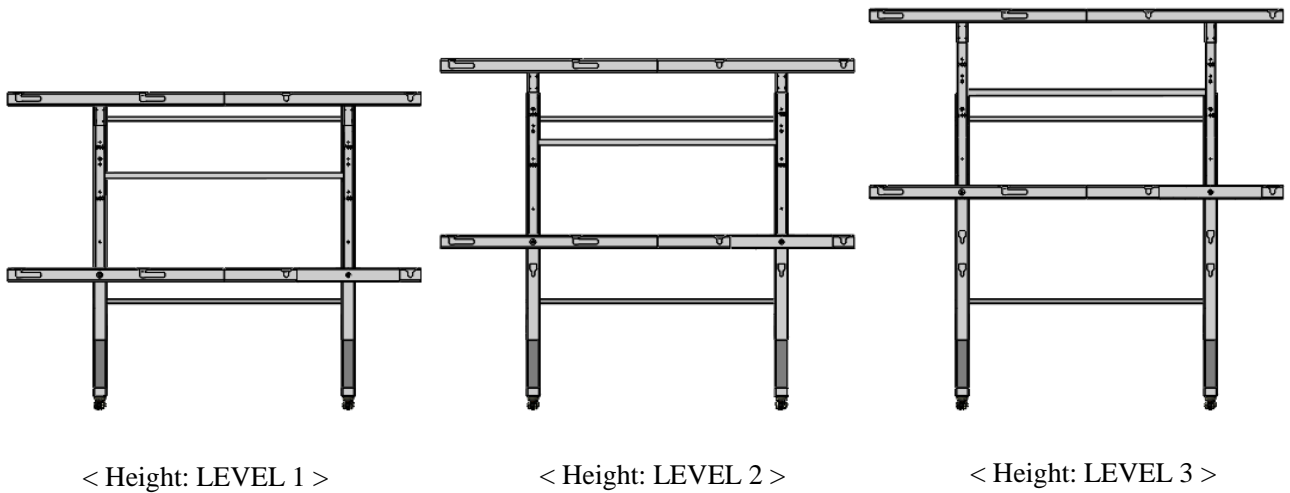

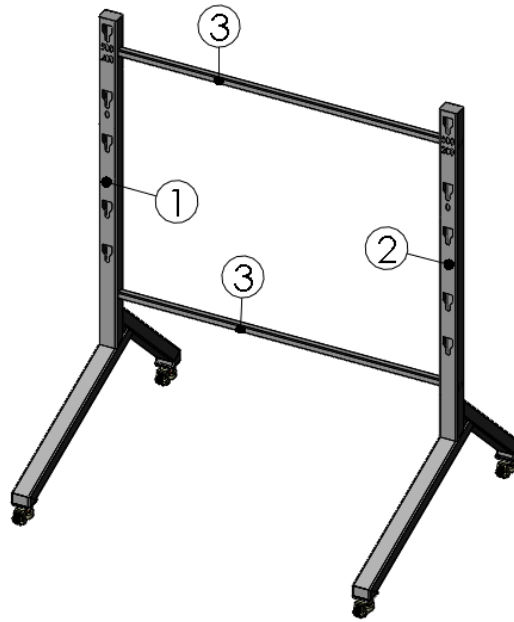

LEVEL	Height
LEVEL 1	≈46cm
LEVEL 2	≈66cm
LEVEL 3	≈96cm

## Packing List







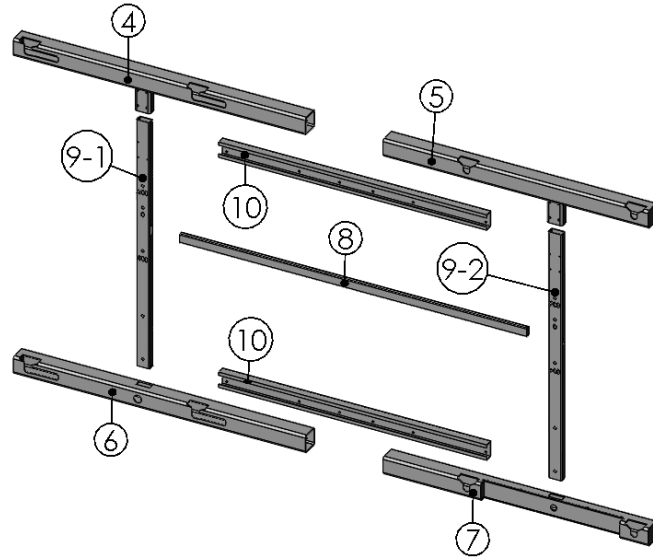

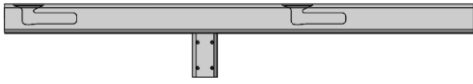

<Main Body Part>

Item	Description	Photo	Qty.
1	Left Support Base		1
2	Right Support Base		1
3	Horizontal Support Beam		2



<Mounting Plate Part>

Item	Description	Photo	Qty.
4	Left Top Support Beam		1
5	Right Top Support Beam		1
6	Left Bottom Support Beam		1
7	Right Bottom Support Beam		1
8	Horizontal Rib		1
9-1	Left Vertical Rib		1
9-2	Right Vertical Rib		1
10	Rib Support		2

11	M6×20mm Hexagon Screw		16
12	M4×15mm Pan Head Screw		48
13-1	Roller1		2
13-2	Roller2		2
14	M12 Nut		4
15	Mounting Lock+Bolt		1
16	M12 Hexagon Socket		1
17	M6 Hex Key		1
18	Screwdriver		1
19	Gloves		4

### Assemble the stand

**Step1. Connect the Support Base (item 1 and item 2) with the support beam (item 3).**

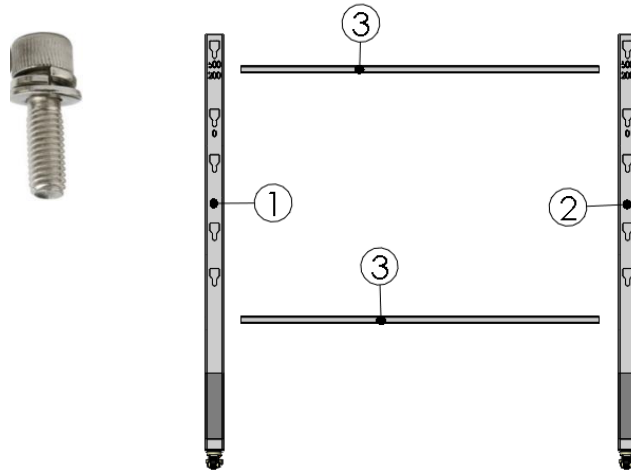

Use 8pcs M6 screws (Item 11) to connect the Item1 and Item 2 with Item 3.

**Step2. Connect the panel mounting plate(Below).**

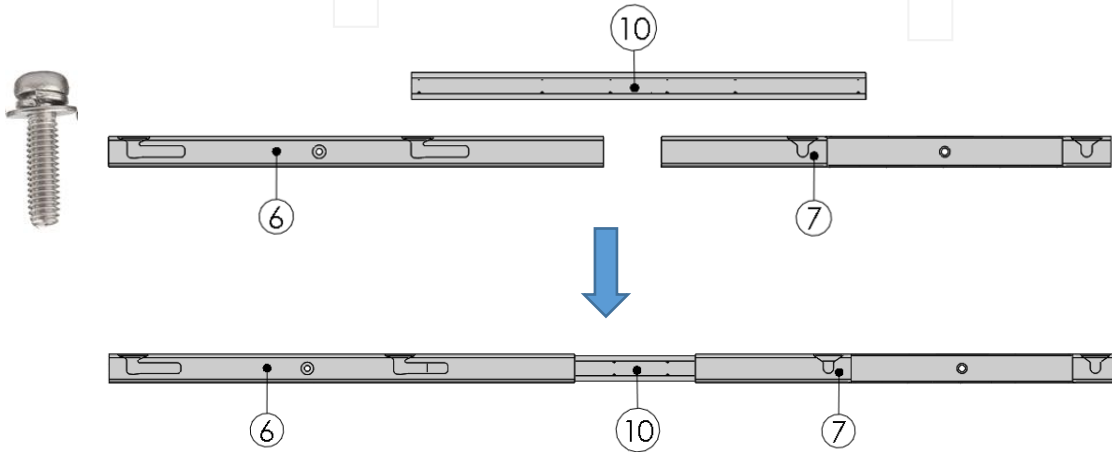

Use 16pcs M4 screws (Item 12) to connect the Item 6 and Item 7 with Item 10.

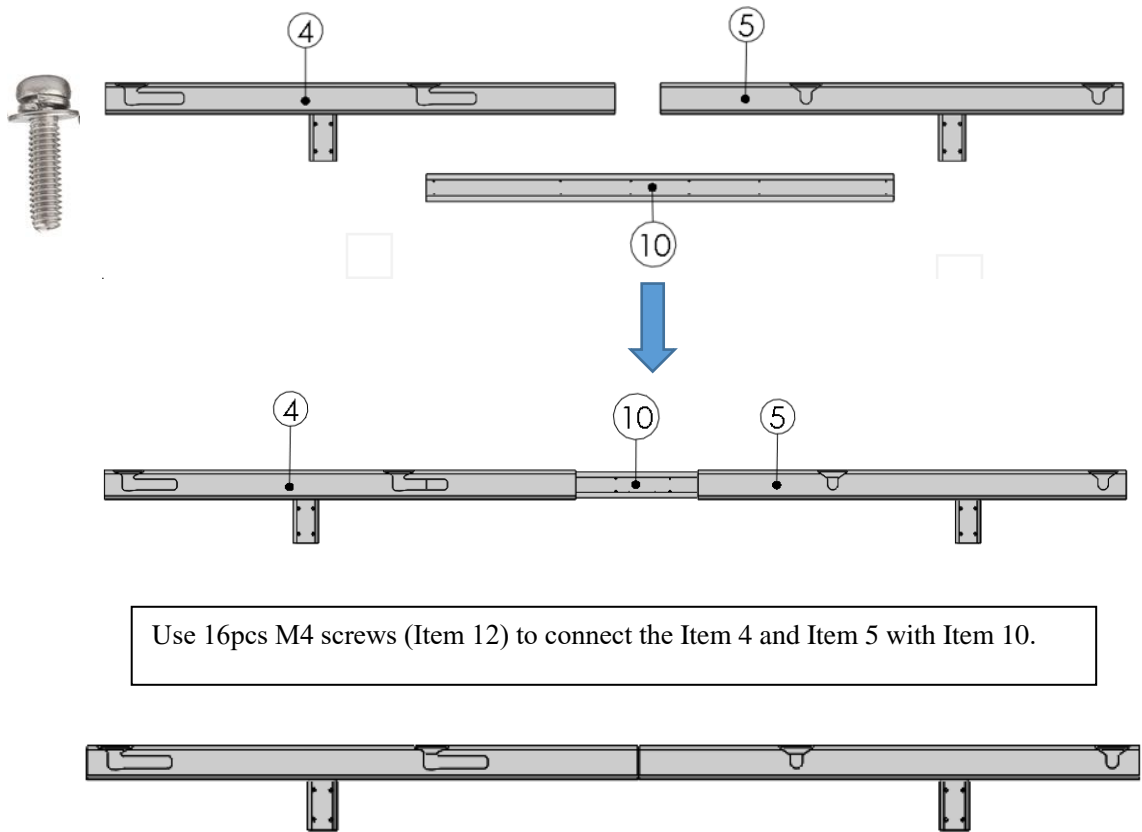
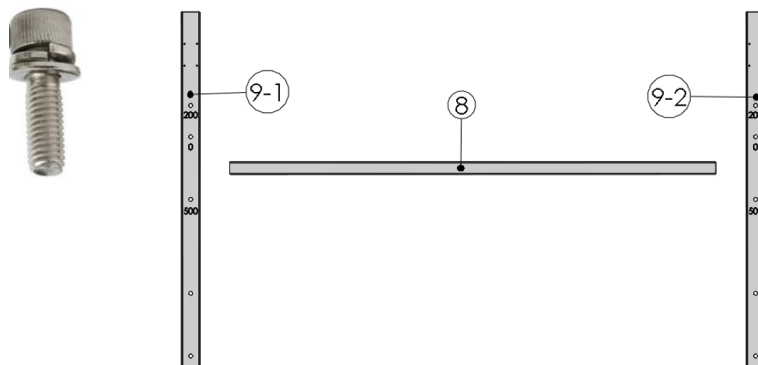

**Step3. Connect the panel mounting plate(Top).****Step4. Connect the vertical rib to the horizontal rib.**

Use 4pcs M6 screws (Item 11) to connect the Item 9 with Item 8.

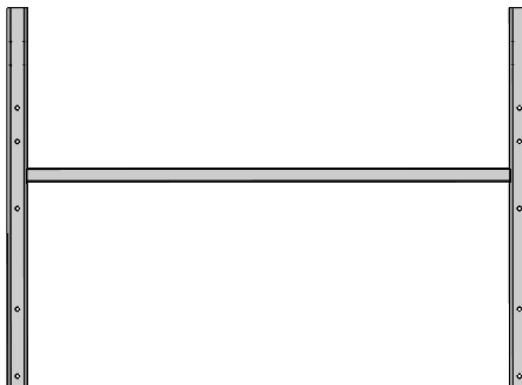

**Step5. Install the assembly parts in step 2, step 3 and step 4.**

Use 16pcs M4 Pan Head screws (Item 12) to connect assembly parts in step 3 with step 4.

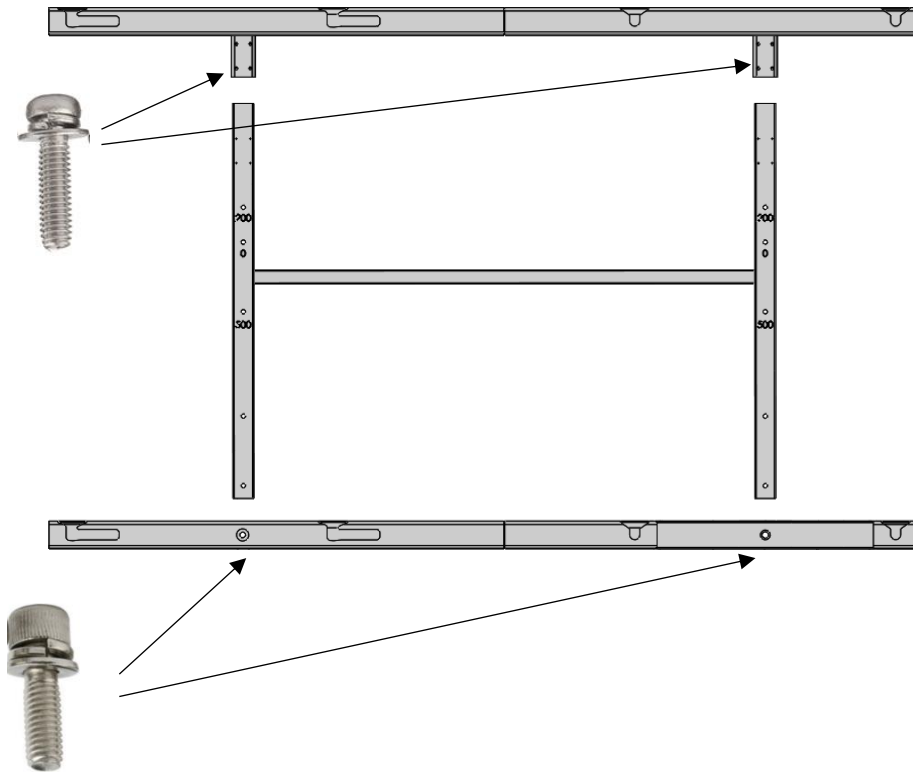

Use 4pcs M6 Hexagon screws (Item 11) to connect assembly parts in step 2 with step 4.



**Step6. Fix the screw as the following position.**

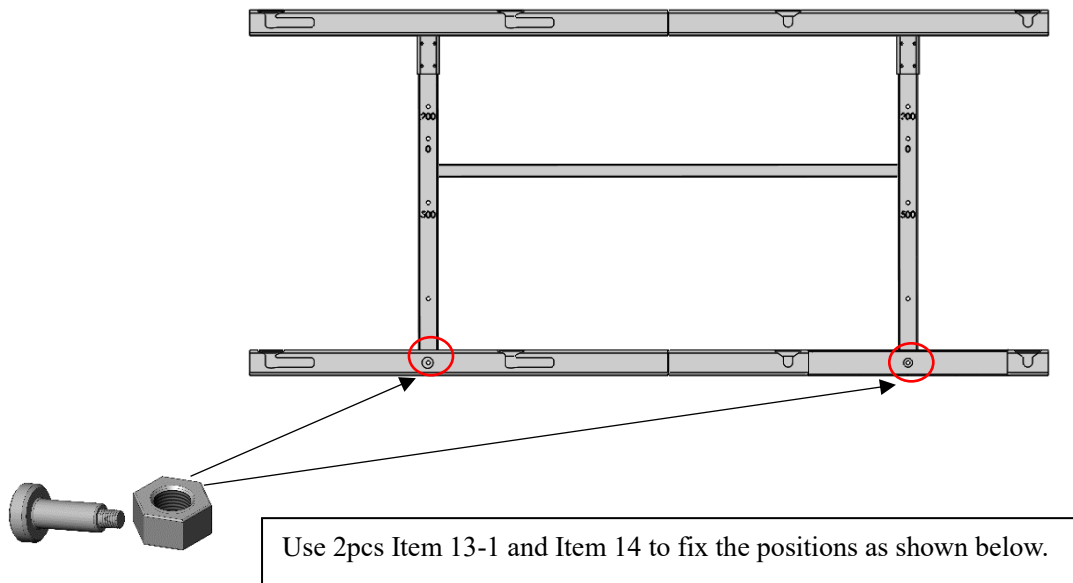

**Step7. Fix the screw as the following position is LEVEL 1, LEVEL 2 and LEVEL 3.**

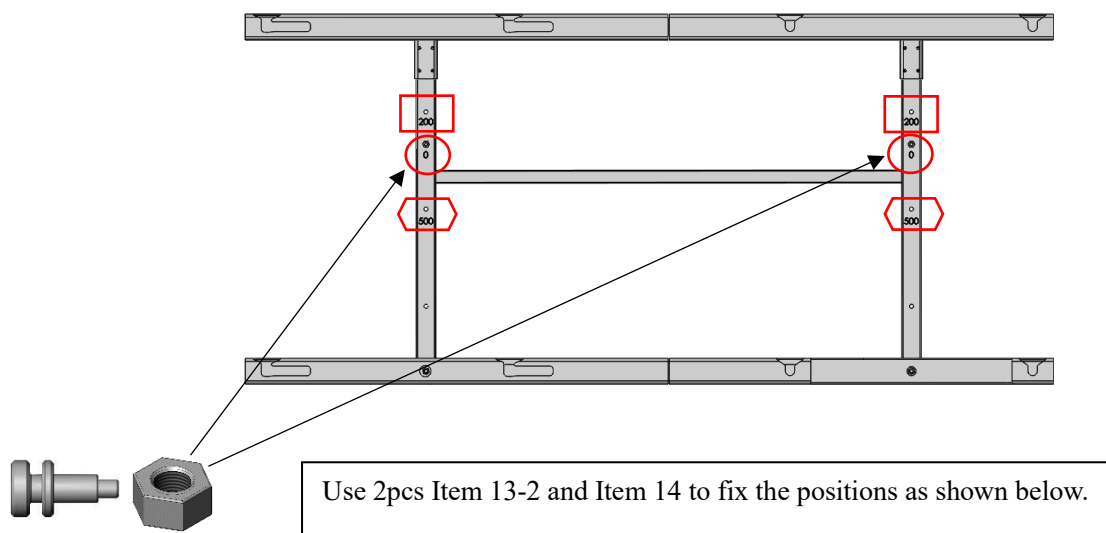

- : The position is for LEVEL 1
- : The position is for LEVEL 2
- ⬡ : The position is for LEVEL 3

## Adjust the stand height.

### Step1. Fixing the screw as the following position.

< LEVEL 1 >

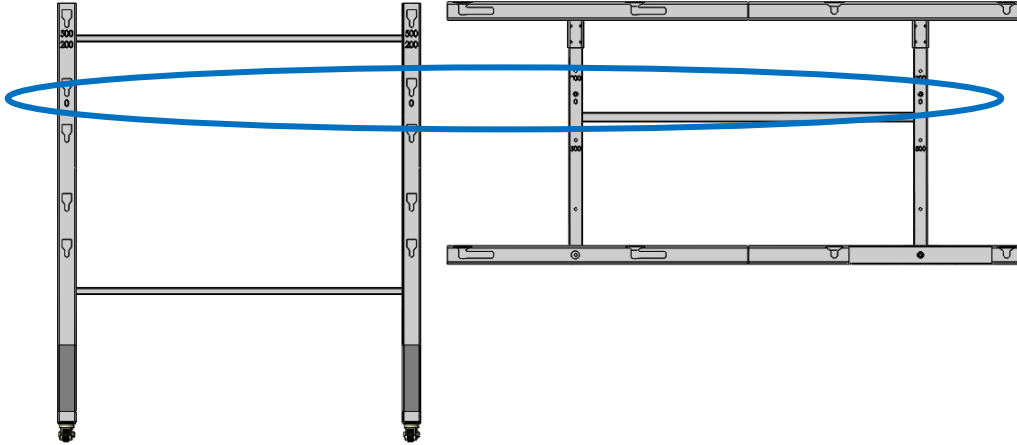

Install the mounting plate part at the "0" LEVEL1 marking of the main body part

< LEVEL 2 >

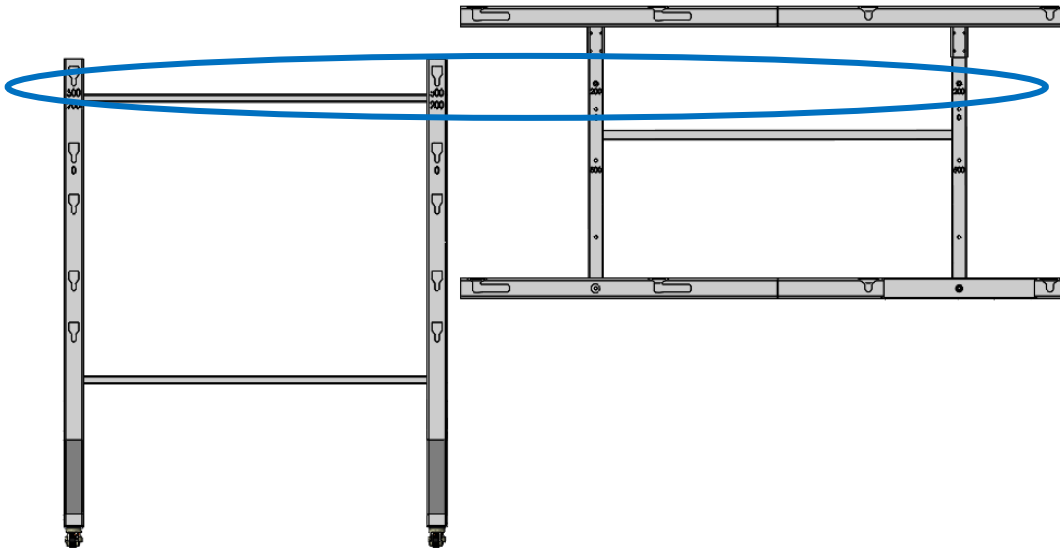

Install the mounting plate part at the "200" LEVEL2 marking of the main body part.

&lt; LEVEL 3 &gt;

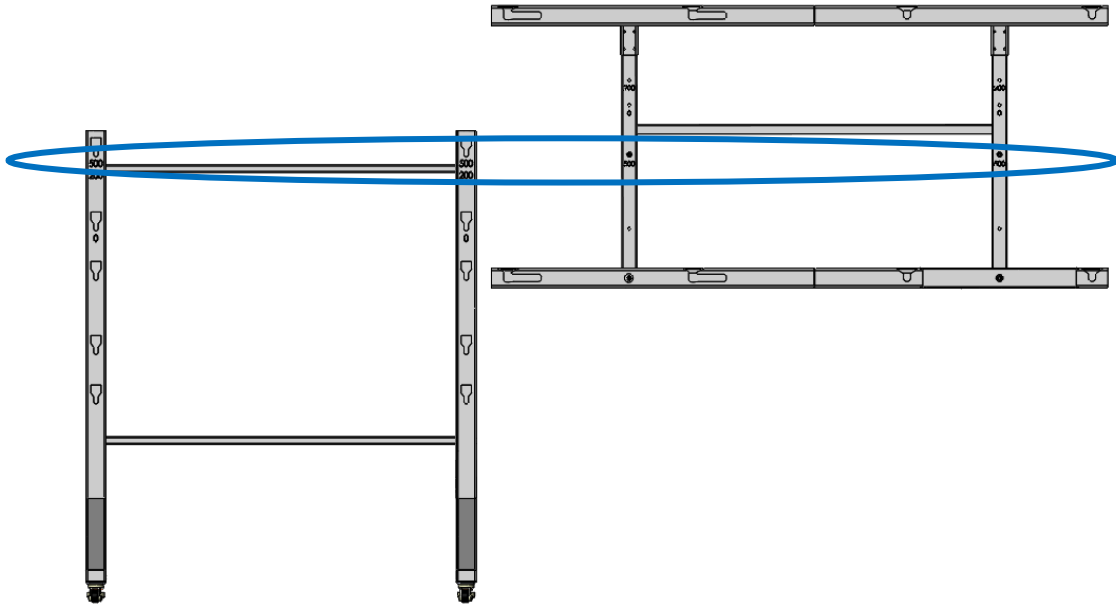

Install the mounting plate part at the “500” LEVEL3 marking of the main body part.

**Step2.** After following the step1, the final assembled product is as shown below.

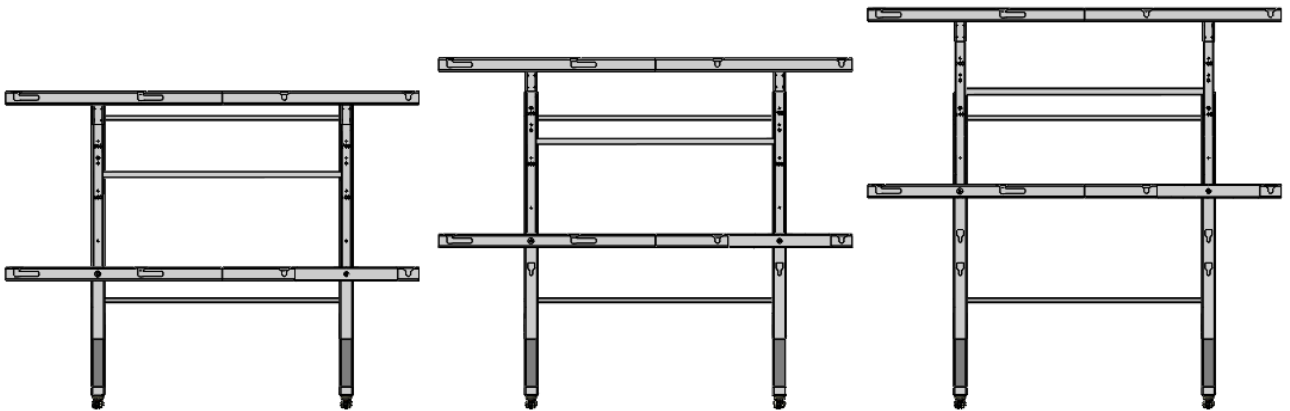

&lt; Height: LEVEL 1 &gt;

&lt; Height: LEVEL 2 &gt;

&lt; Height: LEVEL 3 &gt;

## Screen assembly

The 8pcs fixed mounting lock (item 15) behind the cabinet are assembled to the cabinet and locked with tools.

**Note:** The remaining 7pcs mounting lock are in the accessory list of AIO product.



Mounting lock+ Bolt (item 15)

< Rear View >

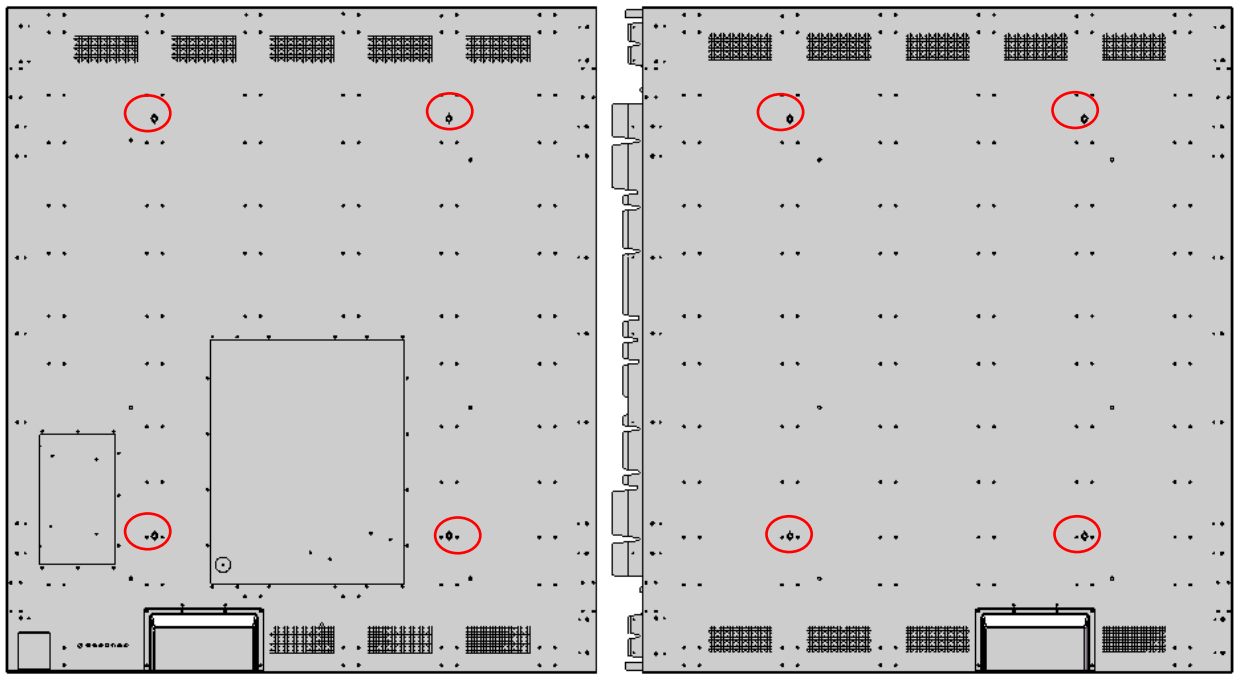

< Right Cabinet >

< Left Cabinet >

Note: Please install the right cabinet onto the stand first and then install the left cabinet.



The model and serial number of the product are located on the back and on one side of the product. Record them below in case you ever need service.

MODEL

SERIAL

NO.

Temporary noise is normal when powering ON or OFF this device.